



Dr. M.G.R. **EDUCATIONAL AND RESEARCH INSTITUTE** **DEEMED TO BE UNIVERSITY**

University with Graded Autonomy Status

(An ISO 21001 : 2018 Certified Institution)

Periyar E.V.R. High Road, Maduravoyal, Chennai-95. Tamilnadu, India.



ADVANCED RESEARCH INSTITUTE **(ARI)**



DRDO Industry – Academia
Conclave DIAC – 2026
20-21 Feb 2026

Introducing ARI

- **Started in 2011 with Dean + 5 Engineers**
- **The People – Dean**
 - + **3 Directors + 16 Scientists + 10 Senior Consultants**
 - + **19 Engineers + 6 Supporting Staff**
- **Patents: 13 Granted;; 25 Filed;**
 - 1 Foreign Patent Granted; Pending in 4 Countries**
 - **1 Trademark; 2 Designs**
- **Projects: 12 Funded projects completed (INR 45.0 Milion)**
 - 10 Projects under Progress (INR 39.0 Million)**
 - 17 Dr MGR Univ. (Seed) Funded Projects (INR 6.0 M)**

The Philosophy

- **Possible to build a World Class Research Institute even in Private,**
 - ✓ **when we rely on people and their brain power rather than on expensive research infrastructure**

- **Possible to attract smart people for Research (including professionals returning from abroad)**
 - ✓ **when a liberal and decent ambience is provided**

BOARD OF ADVISORS



Dr. Prahalad Tengli
Former Director of Missile,
DRDO, HQ



Mr. Rajagopalan Shankar,
Former Director Combat Vehicles,
DRDO, HQ



Dr. S B Singh,
Former Director
NMRL



Prof Dr. J. Beran
Professor- Textile Machine Bldg
Technical University of Liberec
Czechia

BOARD OF ADVISORS



Er. R. Venugopal,
Former Associate Director,
DRDO-CVRDE



Dr. Chinnia Subramanian,
Senior Consultant-ARI,
EnMat Solutions, Cannada.



Dr. T. Bala Subramanian,
M.S, D.L.O
Dean, SLMCH



Lt Col. CV Gopal (Veteran)
Former Corps of EME &
Former Jt Director, DRDO



Dr. Manmohan Singh,
Former Director, VRDE



Dr. P. A. Lakshminarayanan
Former CTO,
Simpson & Co. Ltd.,
Chennai Adjunct Faculty,
IIT Kanpur.

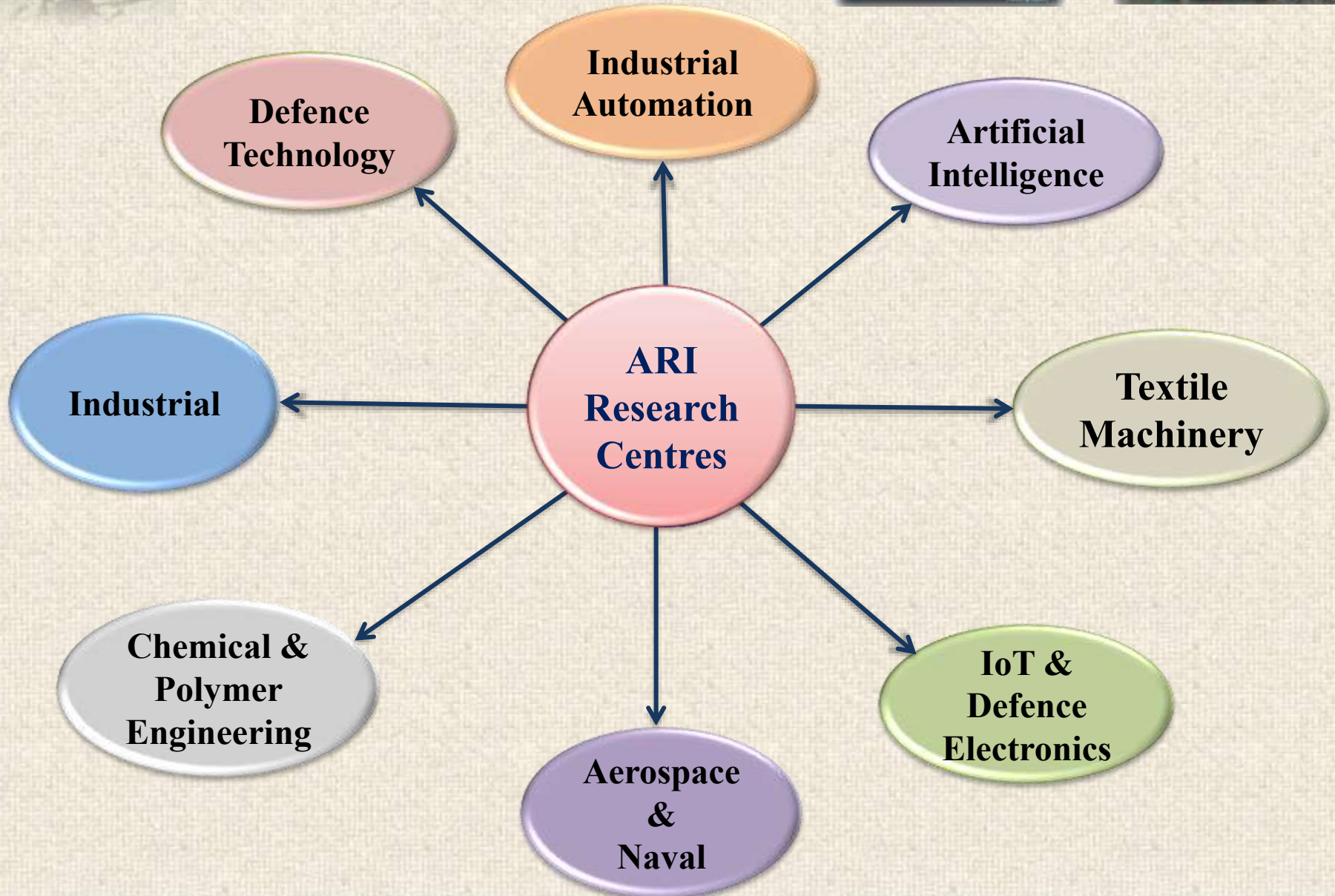



ON-GOING PROJECTS

- **DEFENCE**
- **SPACE**
- **TEXTILE MACHINERY**
- **INDUSTRIAL CONSULTANCY**
- **SEED GRANT PROJECTS**



ON-GOING PROJECTS LIST...



#	Funded by	Title	Images
1	DRDO ARDB	Main Electrical Power Generating Systems for Future UAV/Aircraft – VSCF Generating System	
2	DRDO DRDL	High temperature barrier coating for thermal shielding of critical defense applications (9.50 Lakhs)	
3	DST	High Volume Throughput Machinery for Banana Fiber Extraction (54 Lakhs)	

4	Govt of Tamil Nadu	Value Addition in Kapok Rs.60 Lakhs	
5	Govt of Tamil Nadu	Geotextile Rapier Loom Rs.50.5 Lakhs	





COMPLETED PROJECTS

- DEFENCE
- SPACE
- COIR
- INDUSTRIAL CONSULTANCY
- SEED GRANT PROJECTS

COMPLETED PROJECTS LIST..

#	Funded by	Title	Images
1	 DRDO-ASL	Design of Collapsible Mandrel System (25.00 Lakhs)	
2	 DRDO CVRDE CRDi &CABS	Composite Louvre for Armoured Fighting Vehicles (9.38 Lakhs)	
3		Composite Shell Design, Analysis, Process Details and Tooling of Ellipsoidal Radome (9.97 Lakhs)	
4		Indigenous CRDi Fuel Injection System of Diesel Engine for Armoured Fighting Vehicles (41.00 Lakhs)	

<p>5</p>	 <p>ISRO-VSSC</p>	<p>Collapsible Mandrel System (CMS) for Solid Propellant Casting of 1m Diameter Test Motor (21.29 Lakhs)</p>	
<p>6</p>	 <p>Coir Board (Ministry of MSME)</p>	<p>Development of Plant Machinery for Coir Yarn Spinning (299 Lakhs)</p>	
<p>7</p>	 <p>MILLTEC Machinery Limited</p>	<p>Design and Analysis of Cam and Sieve of Rice Polisher (5.00 Lakhs)</p>	
<p>8</p>	 <p>Anabond Ltd, Chennai</p>	<p>Holographic Interferometry System for Bond Strength of Adhesive Joints (5.00 Lakhs)</p>	

9



**IIT-Indore &
GRP Industries Chennai**

**Design & Development of
Bio-mimic Robotic Fish
Hybrid Vehicle (9.90
Lakhs)**

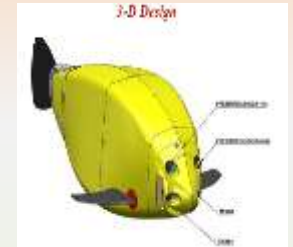



10







Airport Authority of India

**Air pollution monitoring
station (0.60 Lakhs)**

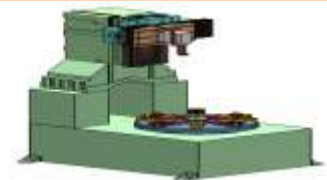

<p>11</p>	<p>UVIRA AEROSPACE, Hyderabad</p>	<p>Hardware & Software Development of DRONE Controller (1.30 Lakhs)</p>	
<p>12</p>	<p>DRDO CABS, Bangalore</p>	<p>Design of Antenna Array with compatible radome for marine Pollution Detection (21.84 Lakhs)</p>	 <p>SLAR Antenna</p>
<p>13</p>	<p>DRDO NSTL</p>	<p>Feasibility Study & Development of a Self- Sustainable Dual Renewable Energy Harvesting System for Unmanned / Autonomous Ocean Surface Vehicle (9.60 Lakhs)</p>	

14	DRDO TDF	Recovery of Lithium precursors from used Lithium ion batteries (57.08 Lakhs)	
15	DRDO TDF	Robotic Propellant machining System	
16	RR Rice Industry	Development of Life Enhancement material for Destoner Machine (3.00 Lakhs)	
17	1. M/S Lalitha Jewellery Mart (P).Ltd. Chennai 2. M/S Enzyrich Biotech Solutions Pvt. Ltd. Pune	Recovery of metals from the waste residue (2.34 Lakhs) Development of Tea and Facemask from Herbal Powder (1.07 Lakhs)	
18	MSME	Natural binder based Coir composite Logistic Pallet (15.00 Lakhs)	

ARI PATENT SUMMARY – 34 Patents

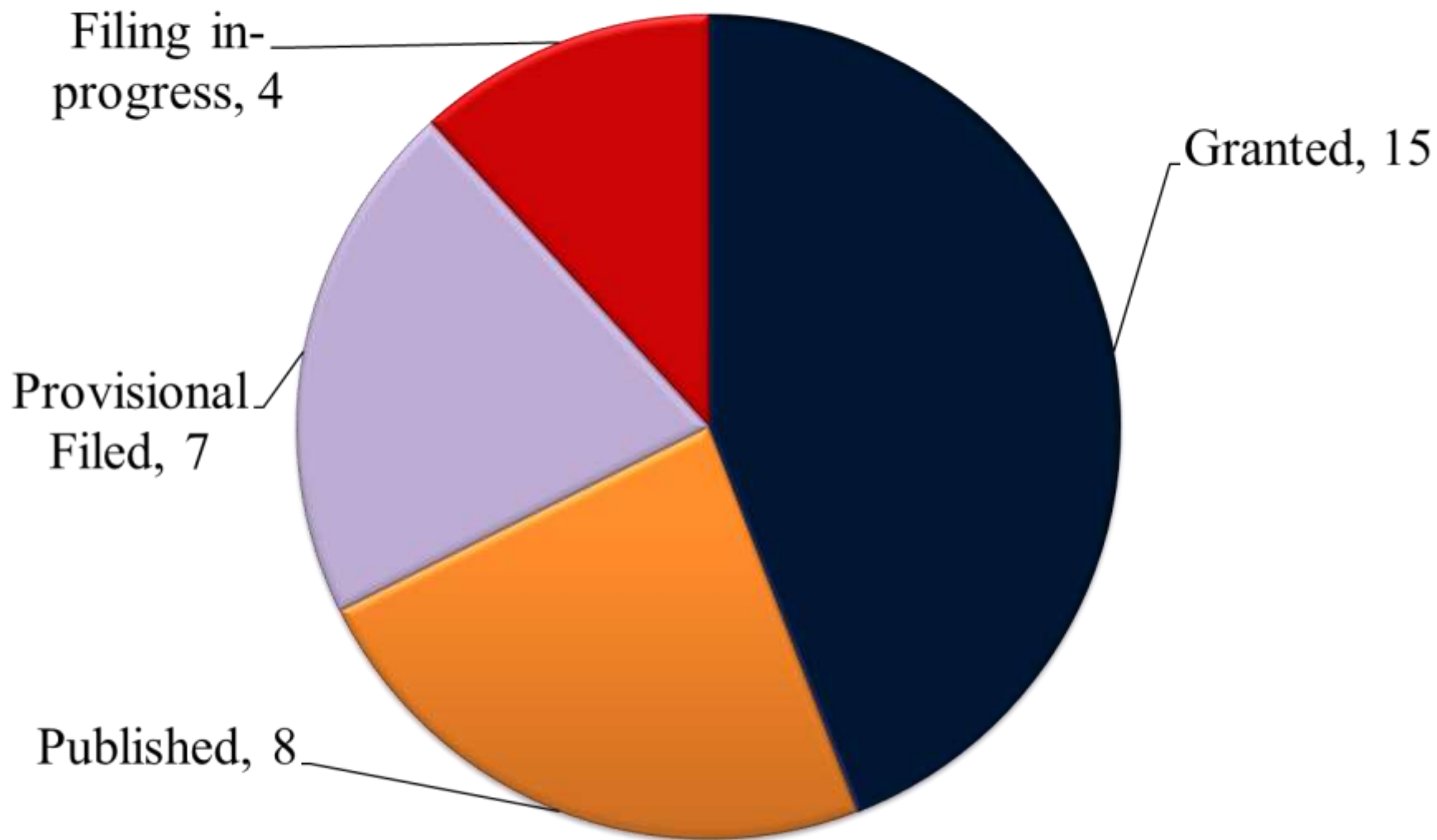

Planned for year (2024-2025) -30 Patents

Flagship Projects...

1. DRDO/ISRO: Propellant casting

Collapsible Mandrel System - 2 Projects Completed

- ✓ 1 Indian Patent
- ✓ DRDO has started implementation

2. Coir Board/MoMSME - New Coir Spinning Machine Development - Completed

- ✓ Rs. 2.99 Cr.(Coir Board) + **Rs. 2.45 Cr.(Dr.MGR DU)**
- ✓ 1 Core Patent in India & 5 Countries
- ✓ 3 Core Patents + 7 Subsystem Patents
- ✓ Tech. Demo Plant installed at CCRI, Alappuzha

Flagship Projects

3. DRDO-NSTL : Autonomous Ocean Vehicles (Surface + Underwater)

- ✓ **Prototype successfully demonstrated to NSTL**
- ✓ **New project on Swam Intelligence in the pipeline**

4. DRDO-CABS : Radome & Antenna for Spacecraft – Projects

- ✓ **Radome Project - Completed**
- ✓ **Antenna Project – Completed**

5. UAV Development (Seed Grant)

- ✓ **Flight Controller for micro UAV (for ADE/DRDO) in the pipeline**

Flagship Projects

6. DRDO-ARMREB : Design of 600HP CRDi System

- ✓ Feasibility study successfully - completed
- ✓ Development phase - on going

7. DRDO-HEMRL : Design and Development of Robotic Propellant Machining System

- ✓ Milestone 1 PDR completed
- ✓ Manufacturing process is to be started

Project Title

“Design and Development of Main Electrical Power Generating System (MEPGS) for future UAV/Aircraft -VSCF Generating system”

Submitted to: AR&DB-DRDO, Delhi
Status: Project Sanction under consideration



MEPGS Generator
Reference image

The objective / Outcome of the Project:

- Design, Development, simulation and analysis on Multistage brushless Generators and embedded controllers using VSCF Concept
- Identification of Various test procedures and test facilities for Multi Stage Generator and Embedded Controller.
- This Technology will be indigenised as the Main Electric power Generating system (MEPGS).
- The successful indigenization of the same will replace the Integrated Drive Generators (IDG).
- Confidence and Expertise acquired by this programme will pave way for development of similar Alternating / Generating system in Aircrafts, Helicopters as well as in Land applications like 9kW, 12kW, 20KW, 90kVA etc.

Coir Yarn Spinning Machine ARICS

The New Generation Machine spins yarn without Core filament



ARI-CS 10K Coir Yarn Spinning Machine developed in the Project
(upto 50 Spinbox per machine possible)
(Patented in India & 5 other Countries)



ADVANCED RESEARCH INSTITUTE (ARI)

DESIGN AND ANALYSIS OF CAM AND SIEVE OF RICE POLISHER

Private Industry : Milltec
Status -Completed

Design and analysis of cam and sieve of horizontal type silky rice polisher 8T-N1 to achieve life improvement of wear components by 20% higher than that of imported makes



Design Innovations

Milltec	ARI
<p>Cylindrical Cam with double end</p> <p>High rise polishing load</p>	<p>Single step</p> <p>Gradual increase in load</p>
<p>Straight ribs</p> <p>Abrupt change of Axial to radial flow</p> <p>Interrupted stirring of grains</p>	<p>1/4 Helical ribs</p> <p>Smooth change of Axial to radial flow</p> <p>Gradual stirring of grains</p>

1st Stage Cam

2nd Stage Cam

Sieve

Life Comparison

MAKE	CAM LIFE IN MONTHS	SIEVE LIFE IN WEEKS
JAPANESE	33	12.4
GERMAN	30	12
Indian Industry	12	6.1
ARI DESIGN	39.6	15.6



ADVANCED RESEARCH INSTITUTE (ARI)

DESIGN OF COLLAPSIBLE MANDREL SYSTEM (CMS)



P
A
T
E
N
T

G
R
A
N
T
E
D

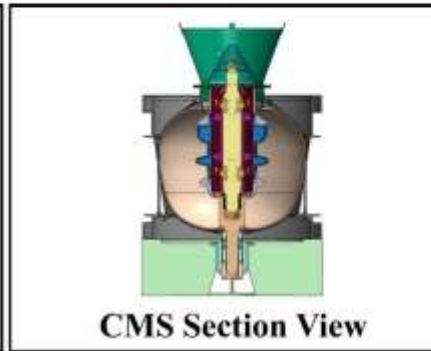
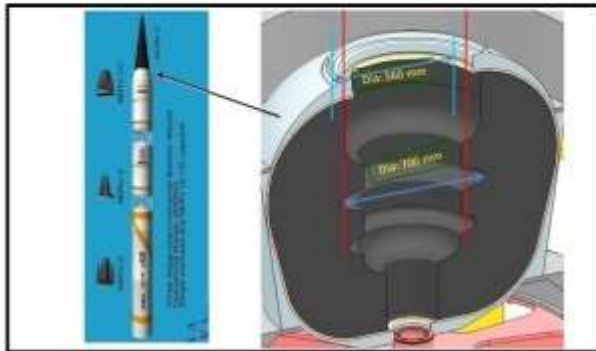

CMS Section View

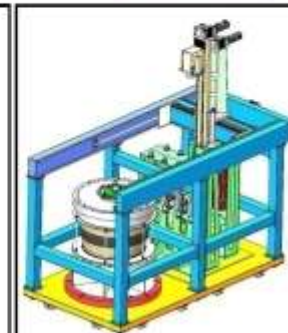

CMS with ADU

Design Innovations

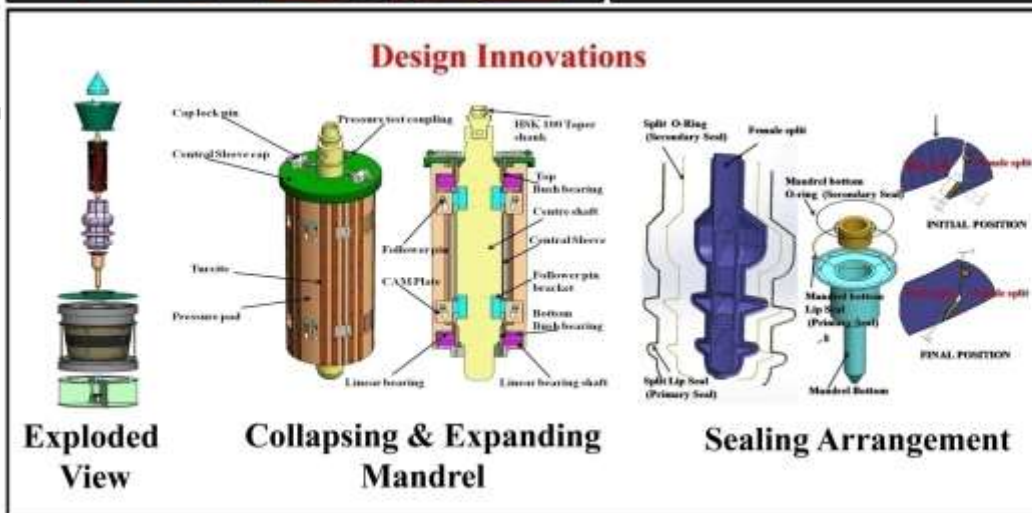

P
A
T
E
N
T

G
R
A
N
T
E
D

Cost Saving Table

Cost Saving in Proposed Design

Parameters	Proposed Design
Cost saving in machining	Rs. 5,52,000
Cost saving in Propellant	Rs. 6,04,300
Total Cost Saving / Motor	Rs 11,56,300

Comparison

Parameters	Current Practice	Proposed
Machining Time	24 days	1 day
Propellant Wasted	139 kgf	27 kgf
Annular Gap	42 mm	62 mm



ADVANCED RESEARCH INSTITUTE (ARI)
DR. M.G.R. EDUCATIONAL AND RESEARCH INSTITUTE
MADURAVOYAL, CHENNAI-600095



Collapsible Mandrel System (CMS) for Solid Propellant Casting of 1m Diameter Test Motor : Lab -ISRO

Status

- **TSM300 test motor for validation and realisation**
- **Conceptual models were reviewed by VSSC**
- **Fabricated system was tested by VSSC through dummy propellant casting**
- **Submitted Project Completion report**



**Isometric View of CMS
with Motor**



**CMS Expanded
Condition**



ADVANCED RESEARCH INSTITUTE (ARI)

STUDY AND DEVELOPMENT OF COMPOSITE LOUVRE FOR ARMOURED FIGHTING VEHICLES

Lab - CVRDE
Status - Completed

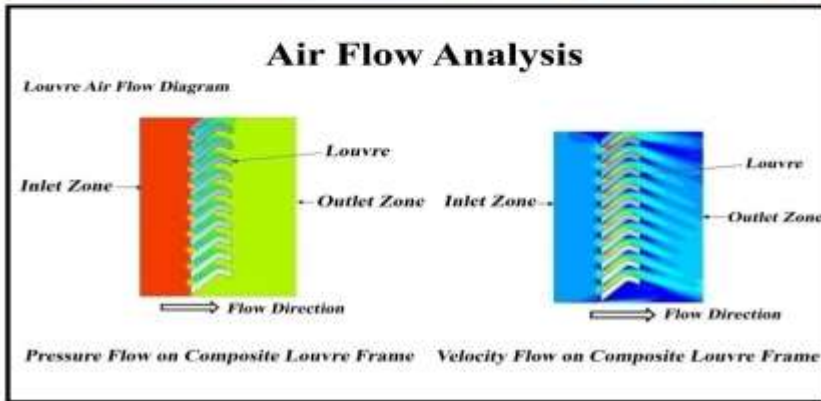
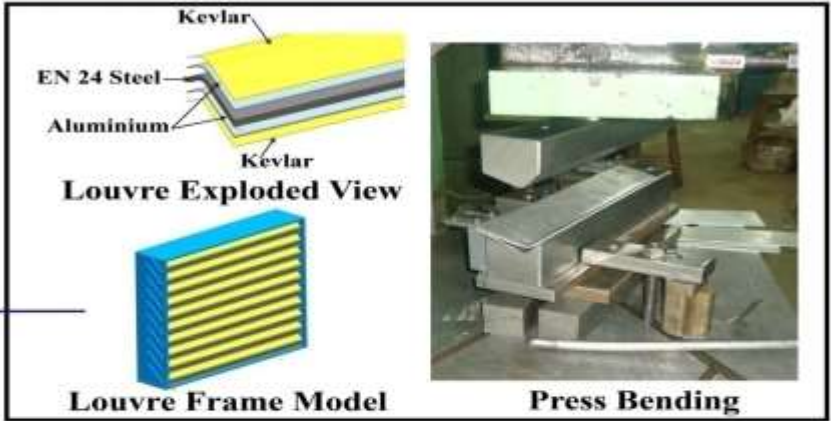



ADVANCED RESEARCH INSTITUTE (ARI)

COMPOSITE SHELL DESIGN, ANALYSIS,
PROCESS DETAILS AND TOOLING OF
ELLIPSOIDAL RADOME

: Lab -CABS



Status -

Completed



Radome Model

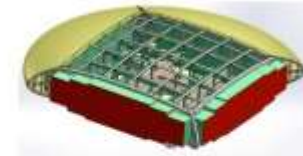

Radome Exploded View

Design Innovation



Internal Structure of Radome

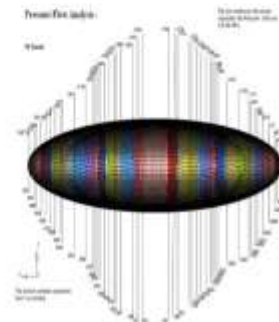

Pressure Flow Analysis

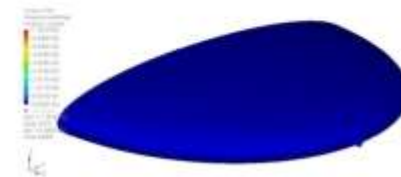

Bird Hit Analysis

Feasibility Study for Design, Manufacturing & Testing of CRDi Fuel Injection System of Diesel Engine for Armoured Fighting Vehicle (AFV)

**Funded by: DRDO Under Grant-in-Aid Scheme of ARMREB,
Lab – CVRDE Status: Completed**



AFV

Indigenous Design and development of CRDi system which includes Critical Assemblies like Common Rail, Fuel Pump, Valves and Injector for High Power Heavy Duty 600hp Diesel Engine of Armoured Fighting Vehicles(AFV).



600 hp Engine

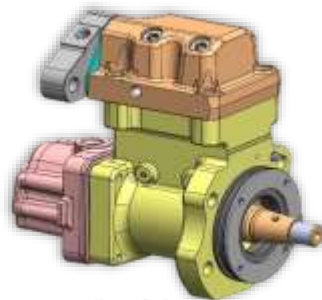

Fuel Pump



Common Rail



Fuel Injector

Feasibility Study & Development of a Self-Sustainable Dual Renewable Energy Harvesting System for Unmanned/Autonomous Ocean Surface Vehicle

To design and develop and experiment a fully renewable energy self-sustainable power pack for autonomous Smart Ocean surface vehicles.

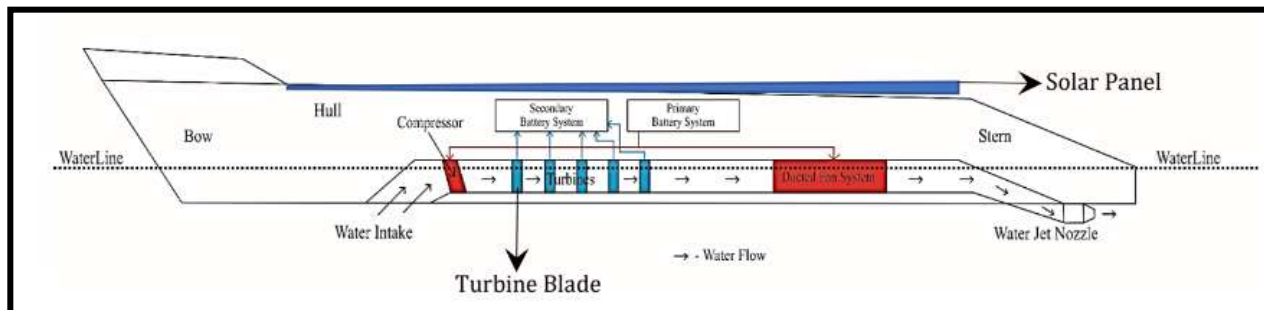



ARI - Defence Design Centre

Technical Design Consultancy to Airflow Equipments Private Limited

Collaborating DRDO Lab : Mobile System Complex (MSC)

Status - Completed

Objectives:

Design and Manufacturing drawing preparation of a Railway Wagon for Defence Application,

- Hood structure assembly,
- Over Head Electricals (OHE) Skewing Mechanism,
- Launch Platform,
- Wagon Levelling Mechanism.



Split Hood Opening Mechanism

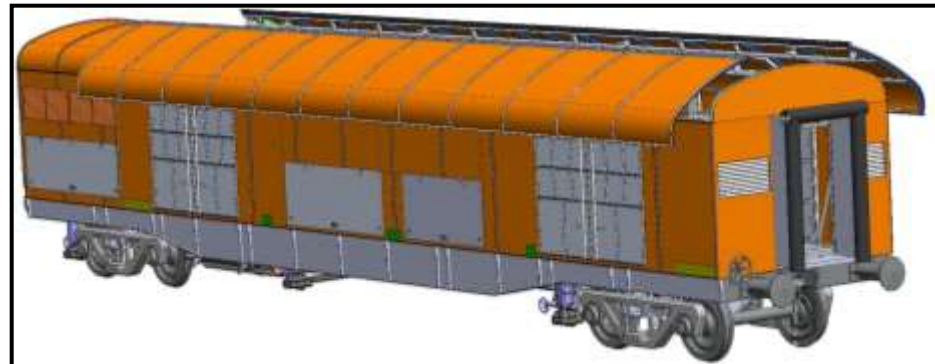
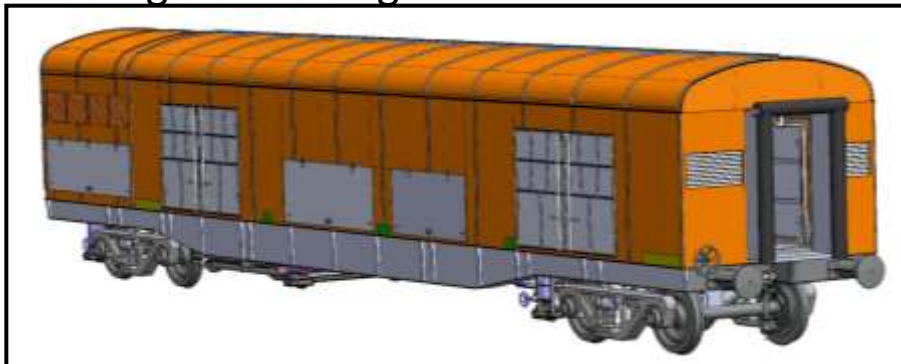

Design and Analysis of Sub-systems - Railway Wagon for Defence Application

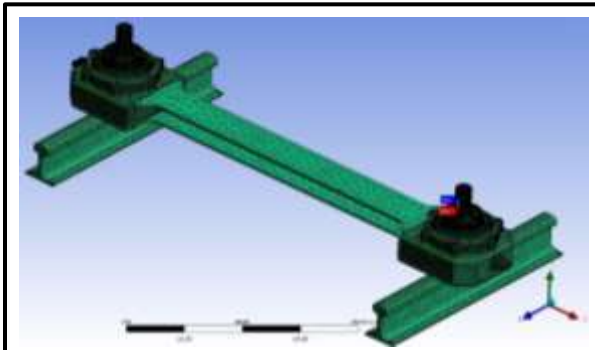

Over Head Electricals (OHE) Skewing Mechanism



Hydraulically Operated Levelling Mechanisms

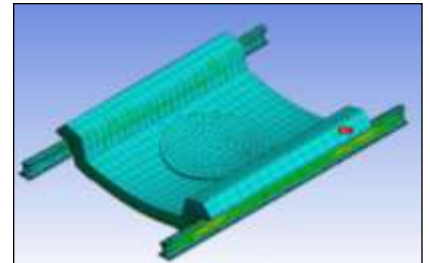
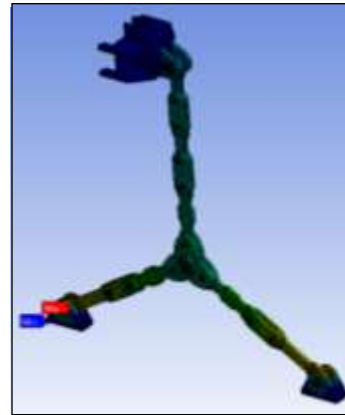

Launch Platform

Deep sea drop camera with underwater light

To design and develop Deep sea drop camera with underwater light of 10,000 lumens for underwater deep sea application at depth of 1000m (100Bar)

Status - Testing
Lab -CMLRE

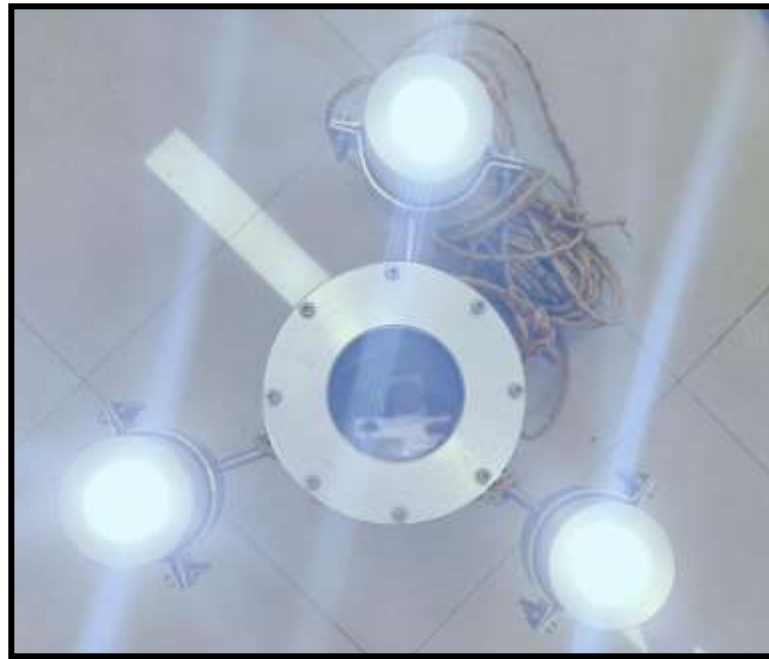

Development of Common Rail Direct injection (CRDi) system for a 600 HP High Power Diesel Engine of Armoured Fighting Vehicle

Status - DRDO Governing Council Sanctioned the Project & Dropped

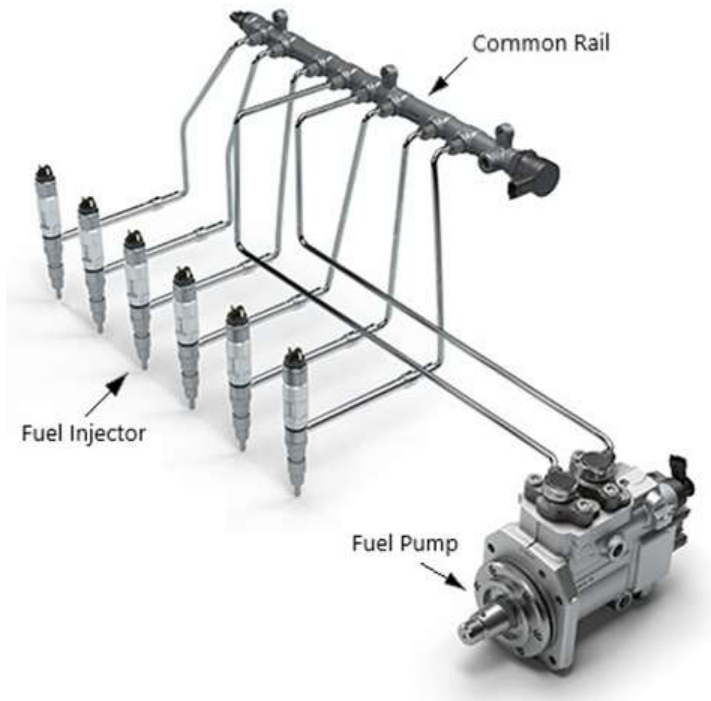

ARI START-UP Profiles...

1. Dr MGR ARI TECHNOLOGY INNOVATIONS

Activity:

**R&D Products for solid propellant machining & lithium
Recovery**

2. Dr MGR ARI NAVAL & AEROSPACE INNOVATIONS LLP

Activity:

R&D Products for Naval and Aerospace Application

3. MGR ARI MODERN COIR MILL MACHINERY LLP

Activity:

To manufacture and market machinery for coir/textile mills

4. Dr MGR ARI Hackberry Automation & Robotics

Activity:

**IoT Manufacturing and marketing of smart switches & other
Devices**



Recovery of lithium precursors from used lithium-ion batteries



Separation of Lithium from used Lithium Ion

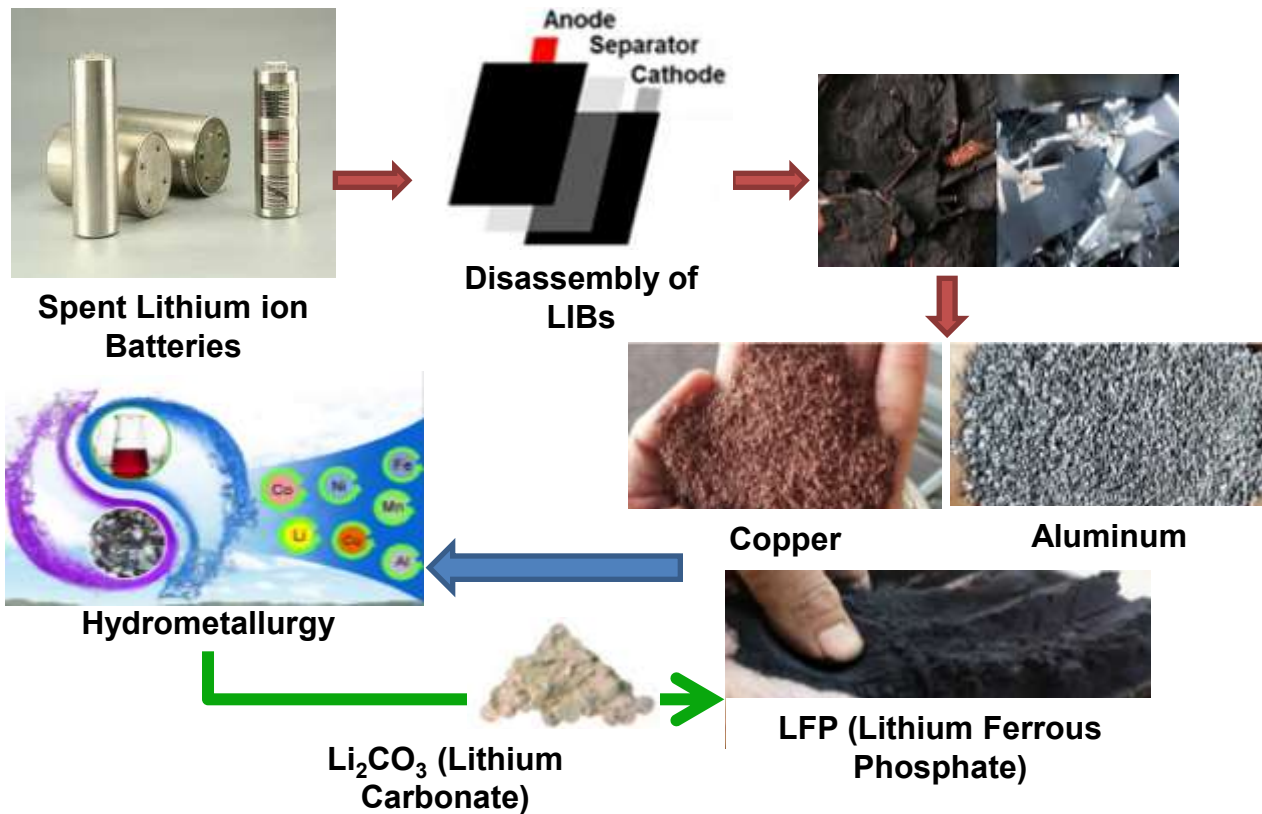

Status - Completed

Lab -NSTL

“Design and Development of Robotic Propellant Machining System”

Robotic Propellant Machining System (RPMS)



Capabilities:

- 3 Degrees of freedom (DOF)
- Safe, Reliable and Precise machining of Axisymmetric slots

PROJECT NO.	DTDF/06/13656/TDF- Proj/HEMRL/D2D/ RPMS/Dr.MGR- ARI/2022/M/C/01/DGTM/DTDF/GI A/22-23/171
PROJECT COMPLETION DATE (PDC)	June, 2026
TOTAL COST	Rs.94,50,000/-

PROJECT OBJECTIVE

- To develop a system to achieve the intricate axi-symmetric solid propellant port configuration through two approaches:
 - a) Robotic propellant machining system and
 - b) Collapsible Split Mandrel System (without / with minimal trimming)
- The developed systems should have safety features that are compatible for solid propellant.

PROJECT DELIVERABLES

- Robotic Propellant Machining System (RPMS) for Motor-A.
- Split Mandrel System (SMS) for Motor-A.

CURRENT STATUS OF THE PROJECT

MILESTONE-3 (Development and Fabrication)

DR MGR - ARI TECHNOLOGY INNOVATIONS PRIVATE LIMITED

Recognized as a startup by DPIIT, MSME approved and UDYAM Certified

Adayalampattu, Maduravoyal, Chennai.

Email: jayaseelan.mech@drmgrdu.ac.in, Phone: 9840856291

Split Mandrel System (SMS)

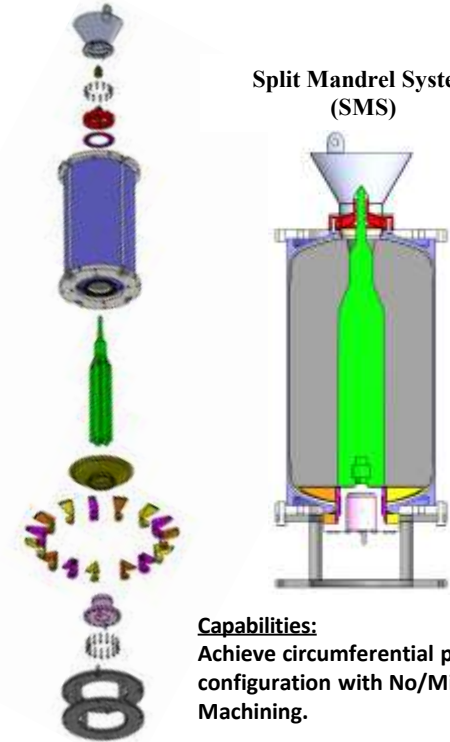

Capabilities:

Achieve circumferential port configuration with No/Minimal Machining.



Development Agency(DA)



Academic Partner



Incubator



TECHNOLOGY DEVELOPMENT FUND

धन्यवाद



Thank You

நன்றி



ధన్యవాదాలు

ధన్యవాదగా
ళు

